



TCA-OEL

Low Level Lightweight Split Automatic

The TCA-OEL is a front line fully automatic split wheel bin lift with the following key features;

- **Efficiency,**

a fast automatic cycle time of 7.0 seconds plus dwell time, which can be adjusted between 0.5 and 1.5 sec.

- **Flexibility,**

because the TCA-OEL is a genuine low level bin lift that offers a hand loading access height of approx. 1.20m. Yet with the plate up the rave rises to 1.6m to give considerable hopper capacity.

- **Low weight,**

the TCA-OEL weighs only 520 kg.

- **Smooth Operation,**

the unique hydraulic block allows for a two stage movement which means that containers rise smoothly and slowly before accelerating to the full tip position, ensuring maximum safety and maximum efficiency.

- **Practical operation,**

increased ground clearance coupled with automatic reverse raise means that the TCA-OEL is as invulnerable to damage as it possibly can be.

- **Automatic shaker,**

an adjustable automatic bin shaker allows 'sticky' materials such as grass cuttings to be handled with ease.

- **Diagnostics,**

a text display is mounted in a durable box on the side of each bin lift to provide simple diagnosis in order to minimise down time.

- **Construction,**

the bin lift chairs are constructed from laser cut high tensile steel - which offer unparalleled strength but not excessive weight.

- **Waterproof,**

the electrical system is located in the proven IP67 box.

- **Containers,**

trade containers, at the turn of a switch the TCA-OEL can be changed over into manual or trade mode to lift the full range of four wheeled containers including Paladins bin fitted with conversion bars.



TCA-OEL



Control: Manual, EN 840.1 (80 - 390 ltr containers).
 EN 840.2 (500 - 1200 ltr containers).
 EN 840.3 (770 - 1300 ltr containers).
 Paladin bins fitted with conversion bars.

Power: Electric / Hydraulic.
 Electric; 24V DC, 10A, 16 pin electrical connection.
 Hydraulic; minimum 40 L.min., maximum 60 L.min., Pressure 180 bar.

Lifting capacity: 1000N/5000N (100 kg/500 kg).

Weight: 520 kg.

Cycle time: Automatic split 7.5 sec.
 Manual Trade 9,5 sec.

Noise level: ≤ 65 dB (A)

Safety: CE Machinery Directive certification and EN 1501.1 conformity.

Connections: Quick release hydraulic couplings (DIN 2353,NW13 NW20)
 and 16 pin electrical connection.

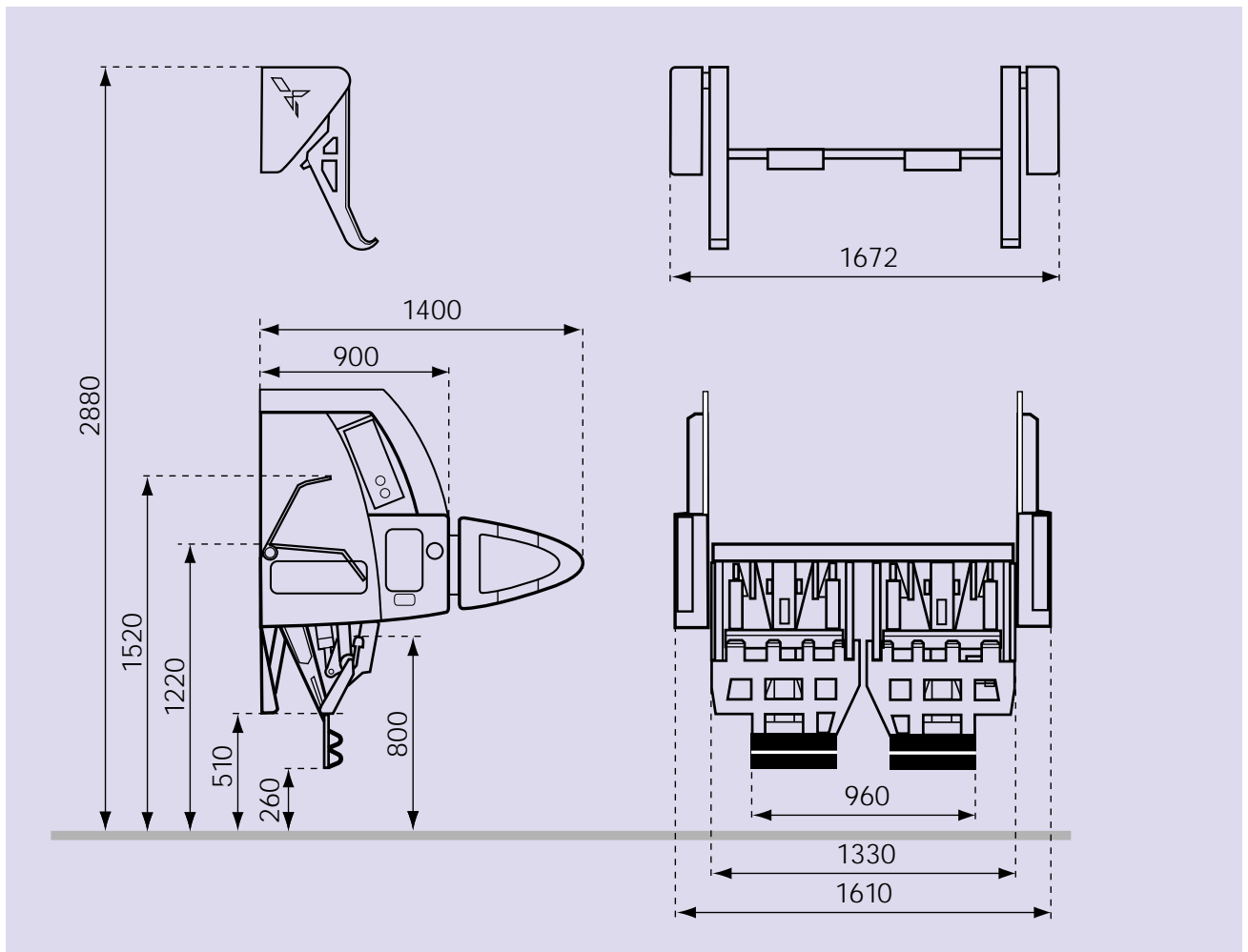

We reserve the right to change the specification of our equipment at any time without prior notification.



TERBERG MACHINES B.V.

P.O. box 127, 3400 AC IJsselstein (U) Holland

Phone 031 2100 600 / Fax 031 30 2100 610

E-mail: info@terbergmachines.nl / www.terbergmachines.nl

